

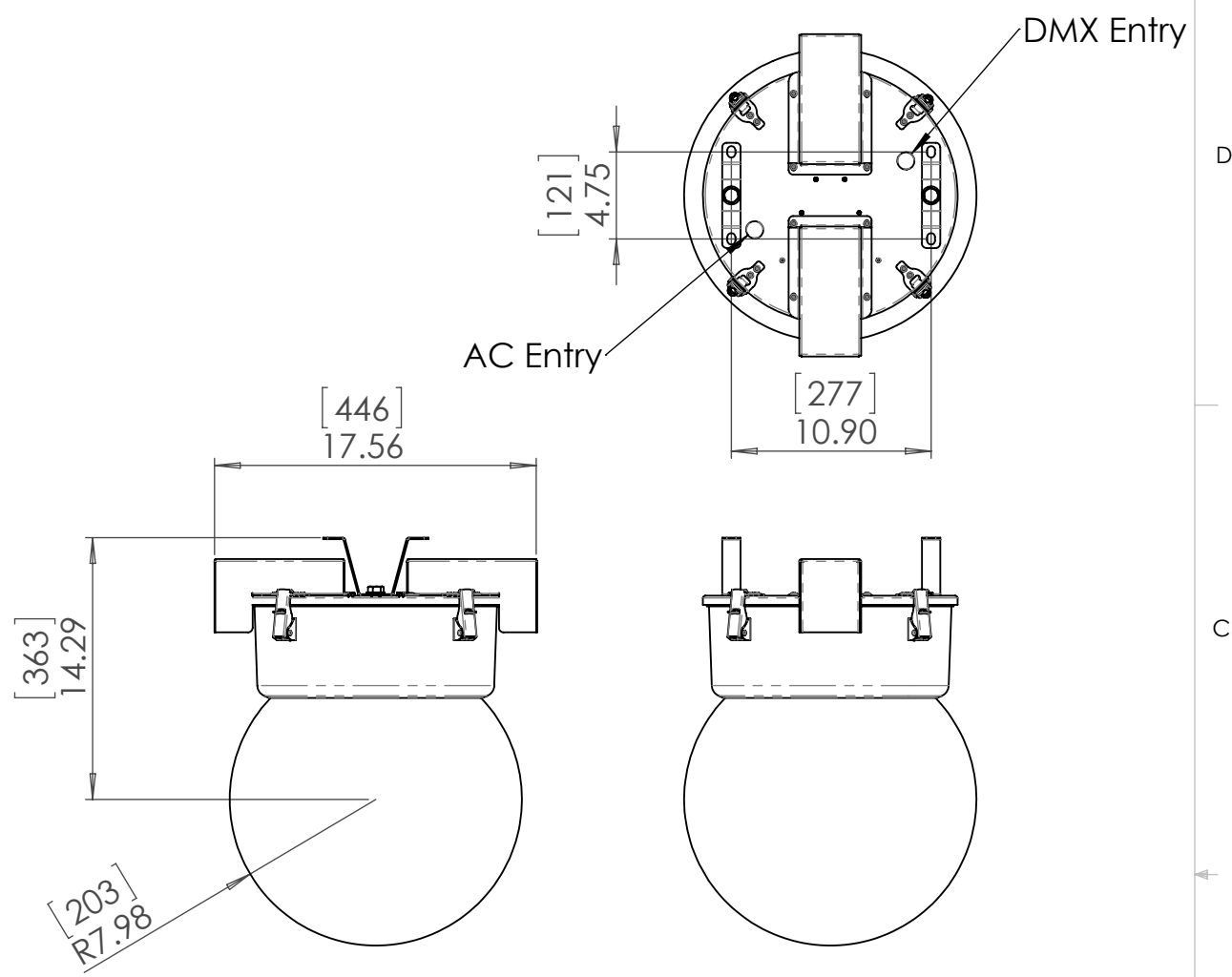

8 7 6 5 4 3 2 1

D
C
B
A

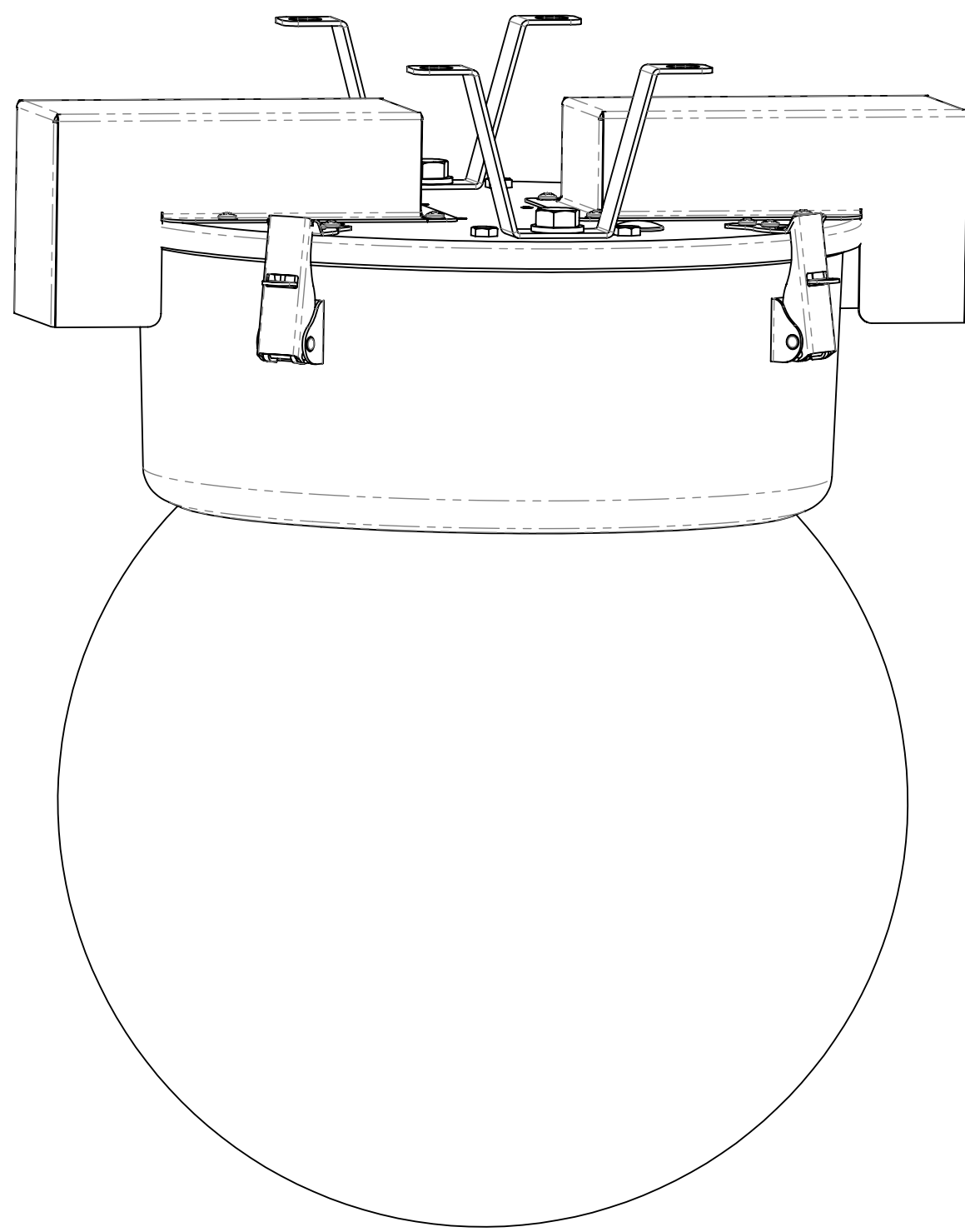

UNLESS OTHERWISE SPECIFIED:
 DIMENSIONS ARE IN INCHES
 TOLERANCES:
 FRACTIONAL ±
 ANGULAR: MACH ± BEND ±
 TWO PLACE DECIMAL ±
 THREE PLACE DECIMAL ±
 INTERPRET GEOMETRIC
 TOLERANCING PER:
 MATERIAL
 Aluminum, stainless steel,
 UV-resistant acrylic
 FINISH
 Powder Coat BK01
 Black
 DO NOT SCALE DRAWING

	NAME	DATE
DRAWN	TB	10/12/2013
CHECKED		
ENG APPR.		
MFG APPR.		
Q.A.		
COMMENTS:		



TEMPEST
lighting inc.

TITLE:
Twister 1800, Base Up

SIZE B	DWG. NO. 1800.xxV	REV 05
------------------	----------------------	-----------

SCALE: 1:10 SHEET 1 OF 1

8 7 6 5 4 3 2 1